

Stand-Up Mobile Workstation

SKU: ADTMWSE5B

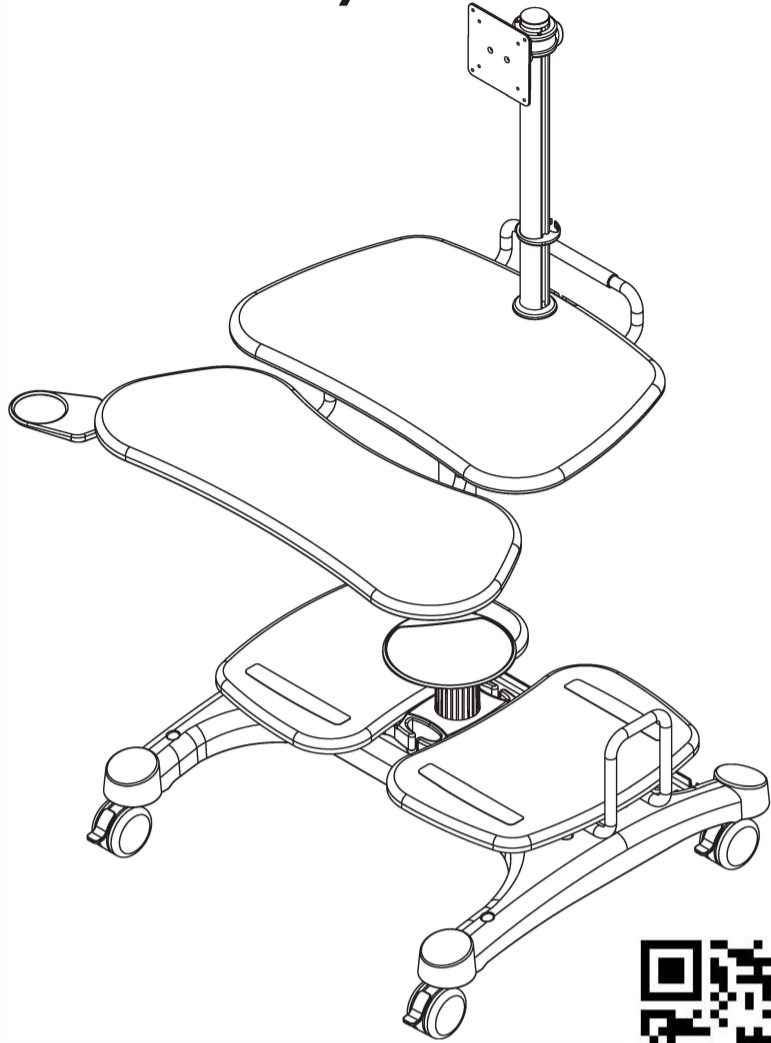







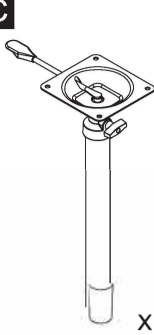
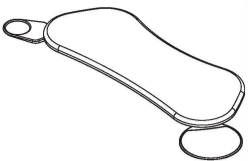
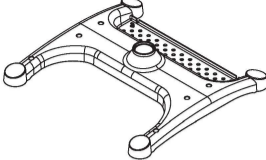

Assembly Instructions

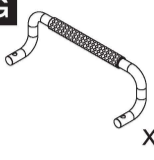
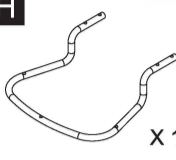
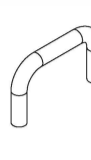
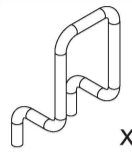

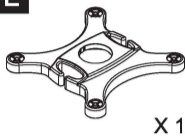
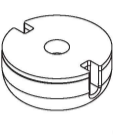

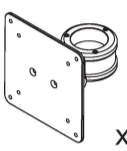
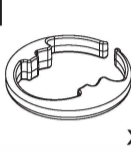

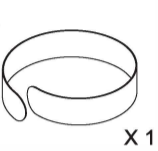

Scan QR code to visit product page

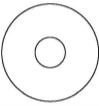
If you have any questions regarding our products, please visit us at displays2go.com or contact D2G Customer Service at 844-221-3388.

Assembly Instruction

Package contents					
A		C		D	
B		E		F	
G		H		I	
J		K		L	
M		N		O	
P		Q		R	
S		T			

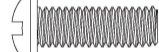
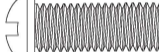
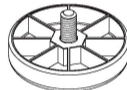
Size comparison chart					
AA		BB		CC	
	M5 Washer X 3		M5x20L X 3		M4x10L X 5
DD		EE		FF	
	M8x12L X 5		M6x25L X 4		M6x30L X 9
GG		HH		II	
	M8x25L X 3		M6x17L X 1		Knob X 2

NOTE: Screw EE is **smaller** than Screw FF. Be advised that these are similar in size, please look carefully to ensure proper construction.

